

## **VOLTAGE MONITORING, PHASE IMBALANCE AND PHASE SEQUENCE RELAY RNPP-312**



## **OPERATING MANUAL**

*Quality Management System of the products designing and production complies with the requirements of ISO 9001:2015, IDT*

Dear Customer,  
NOVATEK-ELECTRO LLC. Company thanks you for purchasing our products.  
You will be able to use properly the device after carefully studying the Operation Manual.  
Store the Operation Manual throughout the service life of the device.

**ATTENTION! ALL REQUIREMENTS OF THIS OPERATION MANUAL ARE COMPULSORY TO BE MET!**



**WARNING! THE DEVICE TERMINALS AND INTERNAL COMPONENTS ARE UNDER POTENTIALLY LETHAL VOLTAGE.**

**TO ENSURE THE DEVICE SAFE OPERATION IT IS STRICTLY FORBIDDEN THE FOLLOWING:**

**– TO CARRY OUT INSTALLATION WORKS AND MAINTENANCE WITHOUT DISCONNECTING THE DEVICE FROM THE MAINS;**

**– TO OPEN AND REPAIR THE DEVICE WITHOUT ANY PROFESSIONAL HELP;**

**– TO OPERATE THE DEVICE WITH MECHANICAL DAMAGES OF THE HOUSING.**

**IT IS NOT ALLOWED WATER PENETRATION ON TERMINALS AND INTERNAL ELEMENTS OF THE DEVICE.**

***ATTENTION! THE CIRCUIT BREAKER (FUSE) OR ITS ANALOG WITH THE CURRENT OF 63 A MAXIMUM OF CLASS B SHOULD BE INSTALLED IN OUTPUT CONTACTS CIRCUIT OF THE DEVICE.***

*To improve the device performance, it is recommended to install the fuse (fuse-link) in the power supply circuit of RNPP-312 (L1, L2, L3) for current 1 A.*

During operation and maintenance, the regulatory document requirements must be met, namely:

Regulations for Operation of Consumer Electrical Installations;

Safety Rules for Operation of Consumer Electrical Installations;

Occupational Safety in Operation of Electrical Installations.

The skilled professionals having studied this Operation Manual must perform installation, adjustment and maintenance of the device.

The device is safe for use under keeping of the operating rules.

This Operation Manual is intended to familiarize you with the design, the requirements for safety, operation and maintenance procedures of the voltage, phase imbalance and sequence relay RNPP-312 (hereinafter referred to as the "device", RNPP-312).

**The device meets the requirements of the following:**

- EN 60947-1;
- EN 60947-6-;
- EN 55011;
- IEC 61000-4-2.

Harmful substances in amounts exceeding maximum permissible concentrations are not available.

**Terms and abbreviations:**

**AR** is automatic reclosing;

**MS** is magnetic starter;

**LINE** – nominal voltage indicators on each phase **L1, L2, L3**;

**NO** – (Normal Open) is normally open relay contact;

**NC** – (Normal Closed) is normally closed relay contact;

**C** – (Common) is common relay contact.

The term "**Normal voltage**" means that the voltage value does not exceed the threshold limit values set by the User.

**1. SERVICE**

**1.1. Device service**

RNPP-312 is designed:

- for monitoring the permissible voltage level;
- for monitoring the correct alternation and absence of sticking of phases;
- for monitoring the full-phase and symmetry of the mains voltage (phase imbalance);
- to disconnect the load in case of improper mains voltage;
- for monitoring the quality of the mains voltage after switching off the load and automatically turning it on after restoring the voltage parameters;
- to indicate the failure in the event of emergency situation and the presence of voltage in each phase.

The device provides the possibility of adjusting the parameters (voltage threshold, time of automatic reclosing and time delay of protection operation), selection of the voltage of the monitored mains (400 V or 415 V) and a set of protective functions.

After restoring the voltage parameters of the mains, the device enables again the load after the reclosing time.

**1.2. Controls, overall and mounting dimensions of RNPP-312**

Controls, overall and mounting dimensions of RNPP-312 are shown in Fig. 1.

- 1 – Rated voltage indicators for each phase (**L1, L2, L3**);
- 2 – Failure indicator (**OFF**);

- 3 – Terminals for power supply connection of 400 V/415 V;
- 4 – Control of setting the threshold for maximum / minimum voltage ( $U_{nom} \pm \%$ );
- 5 – Control of setting the AR time ( $T_{on}(sec)$ );
- 6 – Control of setting the protection operation time ( $T_{off}(sec)$ );
- 7 – Terminals for load connection;
- 8 – Switch of protection operation at the maximum voltage ( $U_{max}$ ) (in position "OFF" – the protection is disabled);
- 9 – Switch of protection operation at the minimum voltage ( $U_{min}$ ) (in position "OFF" – the protection is disabled);
- 10 – Switch of protection operation at voltage imbalance (III) (in position "OFF» – the protection is disabled);
- 11 – Switch of protection operation at phase sequence (≡) (in position "OFF" – the protection is disabled);
- 12 – Switch of rated voltage of controlled mains (**400 V / 415 V**).

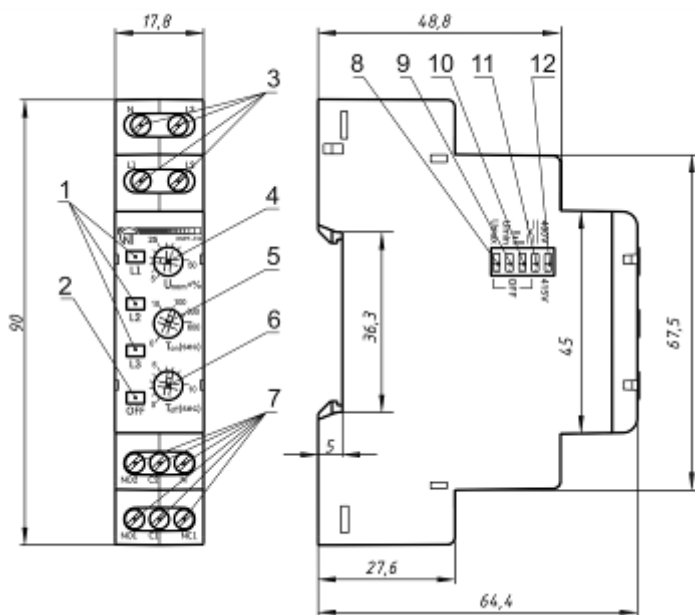

**Fig. 1 – Controls, overall and mounting dimensions of RNPP-312**

**1.3. Operation conditions**

The device is intended for operation in the following conditions:

- Ambient temperature: from minus 35 to +55 °C;
- Atmospheric pressure: from 84 to 106.7 kPa;
- Relative humidity (at temperature of +25 °C): 30 ... 80 %.

*If the temperature of the device after transportation or storage differs from the ambient temperature at which it is*

supposed to be operated, then before connecting to the mains keep the device under the operating conditions within two hours (because of condensation may be on the device elements).

**ATTENTION! The device is not intended for operation in the following conditions:**

- Significant vibration and shocks;
- High humidity;
- Aggressive environment with content in the air of acids, alkalis, etc., as well as severe contaminations (grease, oil, dust, etc.).

**2. TECHNICAL SPECIFICATIONS** The basic technical specifications are given in Table 1.

**Table 1 – The Basic Technical Specifications**

Description	Value
Rated line / phase supply voltage, V	400 / 230, 415 / 240
Mains frequency, Hz	45 – 65
Harmonic composition (unsinusoidality) of supply voltage	EN 50160
Control range of response threshold for $U_{max}/U_{min}$ , as a percentage of rated voltage	5 – 50
Control range of protection operation time, s	0 – 10
Control range of AR time, s	0 – 600
Fixed delay of minimum voltage response, s	12*
Response time when one phase breaks, max., s	0.2
Readiness time when power supply voltage is supplied, max., s	0.2**
Phase imbalance determination value, V	30
Hysteresis of voltage, V	5 – 6
Hysteresis of phase imbalance, V	5 – 6
Accuracy of determination of the voltage operation threshold, max., V	3
Voltage when maintaining serviceability: - for one phase, V - for three phases, V	95 – 450 95 – 450
Power consumption (when load is connected), max., W	1.2
Maximum switching current of output contacts, A	5
Commutation life of output contacts: - under load of 5 A ( $\cos \varphi = 1.0$ ), min., time - under load of 1 A ( $\cos \varphi = 1.0$ ), min., time	100 thousand 1 million
Device service	Switchgear and controlgear
Rated operating condition	Continuous
Protection class rating of the front panel	IP40
Protection class rating of the terminal block	IP20
Electric shock protection class	II
Climatic design version	NC 3.1
Permissible contamination level	II
Oversvoltage category	III
Rated voltage of insulation, V	450
Rated impulse withstand voltage, kV	4.0
Conductor cross-section for connecting to terminals, mm <sup>2</sup>	0.5-1.5
Tightening torque of the terminal screws, N*m	0.4
Weight, max., kg	0.100
Overall dimensions (Fig. 1), H*B*L, mm	90*17.8*64.4
The device installation (mounting) is on standard 35 mm DIN-rail.	
The device remains operational capability in any position in space.	
Housing material - self-extinguishing plastic	
<b>Notes:</b>	
* – When the input voltage drops below $U_{min}$ , the fixed operation time of the device is 12 seconds, if the switches $U_{max}$ and $U_{min}$ are in the "ON" position. With any other combination of switches $U_{max}$ and $U_{min}$ , the device will operate after the delay time set by the User with $T_{off}(\text{sec})$ control. If during this time (12 seconds) the mains parameters change, for example, at the maximum voltage, the device will operate at the smallest of the periods - after the delay time specified by the User, or after the time remaining of 12 seconds.	
** – When working in "Maximum Voltage Control" mode, the ready time is 0.3 seconds.	

### 3. THE INTENDED USE

#### 3.1. Preparation for operation

##### 3.1.1. Preparation for connection:

- Unpack the device (we recommend to keep the original packing for the entire warranty period of the device operation);
- Check the device for damage absence after transportation; in case of such damages detection, contact the supplier or the manufacturer;
- Carefully study the Operation Manual (**pay special attention to the diagram of the device connection to power**);
- If you have any questions regarding the installation of the device, please contact the manufacturer by telephone number indicated at the end of this Operation Manual.

##### 3.1.2. Device connection

**ATTENTION! ALL CONNECTIONS MUST BE PERFORMED WHEN THE DEVICE IS DE-ENERGIZED.**

**Error when performing the installation works may damage the device and connected devices.**

To ensure the reliability of electrical connections the flexible (stranded) wires with insulation for voltage of at least 450 V should be used, the ends of which it is necessary to be striped of insulation for  $5\pm 0.5$  mm and tightened with bootlaces. It is recommended to use the wire with cross-section of at least 1 mm<sup>2</sup>. Wires fastening should exclude mechanical damage, twisting and abrasion of the wire insulation.

**IT IS NOT ALLOWED TO LEAVE EXPOSED PORTIONS OF WIRE PROTRUDING BEYOND THE TERMINAL BLOCK.**

**For a reliable contact, tighten the terminal screws with the force indicated in Table 1.**

When reducing the tightening torque, the junction point is heated, the terminal block may be melted and wire can burn. If you increase the tightening torque, it is possible to have thread failure of the terminal block screws or the compression of the connected wire.

**3.1.2.1.** Enable the necessary protections using protection switches (it. 8 – 11, Fig. 1).

**3.1.2.2.** Set the type of mains used with switch of rated voltage of **400 V / 415 V** (it. 12, Fig. 1).

**3.1.2.3.** Connect the device according to the diagram shown in Fig. 2.

**3.1.2.4.** Using the  $U_{nom} \pm\%$  control (it. 4, Fig. 1), set the required operation threshold for the maximum and minimum voltage as a percentage of the rated supply voltage of the mains.

**Attention! When setting the lower threshold for  $U_{min}$ , the release voltage of the MS must be taken into account.**

**3.1.2.5.** Using the  $T_{off}$  (**sec**) control (it. 6, Fig. 1), set the protection operation time.

$T_{off}$  (**sec**) is the time of protection operation for all types of mains voltage failures, except for the case of voltage drop below 100 V or the break of one or more phases. It is recommended to set the value of  $T_{off}$  (**sec**) for at least 1 second to prevent unnecessary operation caused by the voltage deviation in the mains when heavy duty power consumers are turned on/off.

**3.1.2.6.** Using  $T_{on}$ (**sec**) control (it. 5, Fig. 1) set the reclosing time AR.

$T_{on}$ (**sec**) is the time of automatic reclosing after the device operation and restoration of the mains voltage parameters; on-time is after the rated voltage supply to the device.

It is recommended to set the reclosing time AR for air conditioners, refrigerators and other compressor equipment at least 180 - 240 seconds.

**ATTENTION! In order not to break or turn the control, please do not use excessive force when performing the setting operations.**

**3.1.2.7.** Feed the supply voltage to the terminals of the device.

#### 3.2. The Device Use

**3.2.1.** RNPP-312 can be operated in the following modes:

- "Minimum / maximum voltage control";
- "Minimum voltage control";
- "Maximum voltage control";
- "Phases presence control";
- "Control of incorrect phase sequence and presence of phase sticking";
- "Phase imbalance control".

**NOTE:** The control of the phase presence is kept in any operating mode.

**3.2.1.1.** In "Minimum / maximum voltage control" mode, when the voltage value of the mains is exceeded for the thresholds set by the User, the protected equipment will be disconnected from the mains; the **OFF** indicator will light up on the front panel of the device.

**3.2.1.2.** In "Minimum voltage control" mode, when the mains voltage drops below the threshold set by the User, the protected equipment is disconnected from the mains, the **OFF** indicator will light up on the front panel of the device.

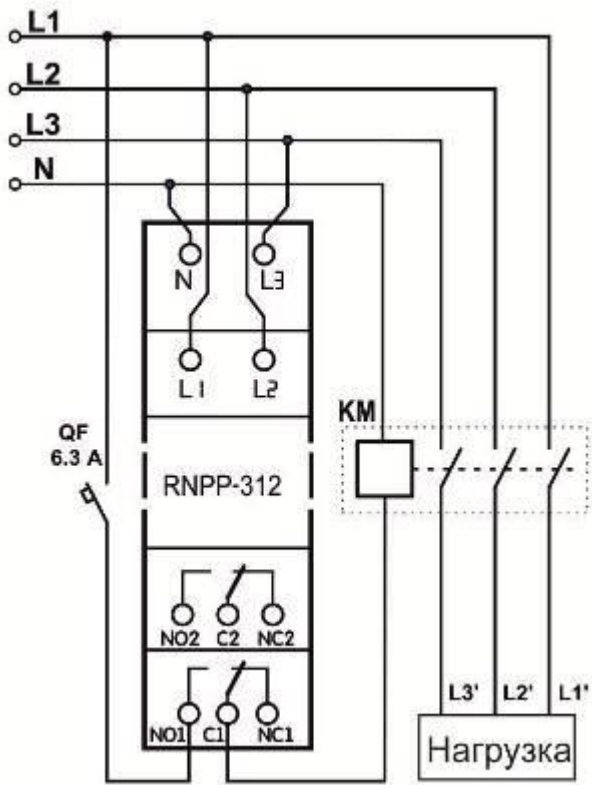

**Notes:** If the device is to be used in the "Maximum Voltage Control" mode (it.3.2.1.3), the MS coil power supply interruption must be connected to terminals **C1-NC1 (C2-NC2)** (inverse logic for enabling). Shift the switch **U<sub>max</sub>** (it. 8, Fig. 1) to the position "ON", and switches **U<sub>max</sub>**, **U<sub>min</sub>** – to the position "OFF".

**Fig. 2 – Connection Diagram of RNPP-312**

**3.2.1.3.** In "Maximum voltage control" mode, when the mains voltage rises above the threshold set by the User, the protected equipment is disconnected from the mains, the **OFF** indicator will light up on the front panel of the device.

**3.2.1.4.** In "Phases presence control" mode, if one phase is broken, one of the **LINE** indicators goes out; the protected equipment is disconnected from the mains; the **OFF** indicator will light up on the front panel of the device.

**3.2.1.5.** In "Control of incorrect phase sequence and presence of phase sticking" mode, if the connection is incorrect or if one of the phases is sticking, one of the **LINE** indicators alternately lights on the front panel of the device, the **OFF** indicator will light up and the protected equipment disconnects from the mains.

**3.2.1.6.** In "Phase imbalance control" mode, when the phases are imbalanced, two **LINE** indicators flash alternately on the front panel of the device, the **OFF** indicator will light up and the protected equipment disconnects from the mains.

**3.2.2.** The device at the output has two groups of independent output changeover contacts (**NO1-C1-NC1, NO2-C2-NC2**). If there is no voltage to the device, the contacts **C1-NC1 (C2-NC2)** are closed, and the contacts **NO1-C1 (NO2-C2)** are open.

When the RNPP-312 is operated, the load is disconnected by interrupting the power supply of the MS coil through **NO1-C1 (NO2-C2)** contacts, **except for the "Maximum Voltage Control" mode in which the device is operated with an inverse switching logic.**

**3.2.3.** After the power is supplied to the terminals of the device, the indicators **L1, L2, L3** turn on. The device goes into the AR delay time mode (set by the **T<sub>on</sub>(sec)** control), while the **OFF** indicator flashes. After the reclosing time has finished, the **OFF** indicator turns off and the device connects the protected equipment to the mains.

In the event of the failure, the reclosing time AR begins immediately after the device disconnects the protected equipment.

**3.2.4.** If the device is used in the "Maximum voltage control" mode, at **normal voltage** in the mains, the device contacts **C1-NC1 (C2-NC2)** are closed, and the contacts **NO1-C1 (NO2-C2)** are open. This is done to ensure that the device in the "Maximum voltage control" mode has never operated for reducing the voltage. In this mode, when the device is turned on for the first time, the reclosing time value (**T<sub>on</sub>(sec)**) is not taken into account.

**Note:** In all operation modes, the device is operated when the phase is broken or the voltage drops below 100 V in one or more phases for the fixed time of 0.2 s, except for the "Maximum voltage control" mode.

**3.2.5.** The options for the status of indicators **L1, L2, L3** and **OFF** are shown in Table 2.

**Table 2** – Status options for indicators L1, L2, L3 and OFF

Indicators L1, L2, L3	Status of indicators L1, L2, L3	Indicator OFF	Status of indicator OFF	Functional status of RNPP-312
● ● ●	Constant lighting of each (all)	○	Absence of light	Value of voltage supplied to each phase is within the limits set by the user for the voltage operation
		●	Flashing (AR time countdown)	
○ ○ ○	Flashing of one (all)	●	Constant lighting	Increase of voltage in one phase (phases)
○ ○ ○	Absence of light of one (all)	●	Constant lighting	1) Lowering the voltage in one phase (phases) below the threshold; 2) Phase failure or under-voltage in one of the phases below 100 V;
○ ● ● ● ● ○	Alternate flashing of two indicators (first the middle and lower lights, then the middle and upper indicators light)	●	Constant lighting	Phase imbalance failure
● ○ ○ ○ ● ○ ○ ○ ●	Alternate lighting (first upper, then middle, then lower indicators light)	●	Constant lighting	Failure due to incorrect phase sequence and the presence of phase sticking

**Note:** The failure is displayed in order of priority:

- 1 – Phase failure or voltage drop below 100 V (highest priority);
- 2 – Phase sequence;
- 3 – Minimum and maximum voltage;
- 4 – Phase imbalance.

### 3.3. Examples of RNPP-312 using

#### 3.3.1. RNPP-312 in "Minimum voltage control" mode:

- Switch **Umin** is in ON position (the device operation for **Umin** is allowed);
- Switches **≡**, **■**, **Umax** are in OFF position (the operation for these failures is not allowed).

If the voltage drops below **Umin**, the device will operate after the **Toff (sec)** time set by the User, the red **OFF** indicator will light up, the corresponding **LINE** indicator (-s) will off. If the voltage drops below 100 V, the device will be operated after 0.2 seconds.

#### 3.3.2. RNPP-312 in "Minimum / maximum voltage control" and "Phases presence control" modes

Switches **Umin** и **Umax** are in ON position. RNPP-312 will operate if the voltage rises above the set threshold after the time **Toff (sec)**, and when it decreases - with the fixed delay of 12 seconds (setting the starting voltage slumps), the red **OFF** indicator will light up. If the phase breaks, the device will operate after 0.2 seconds.

#### 3.3.3. RNPP-312 in "Maximum voltage control" mode:

- Switch **Umax** is ON position (the device operation for **Umax** is allowed);
- Switches **≡**, **■**, **Umin** are in **OFF** position, the indicator **OFF** does not light.

When the voltage rises more than **Umax**, the device will operate after ( $T_{on}(sec) + 0.4$ ) seconds, the red indicator **OFF** will light up.

#### 3.3.4. On delay time

Switches **Umin** and **Umax** are in OFF position.

The protected equipment will be connected after the AR time countdown set by the User with the help of **Toff(sec)** control. In all modes of operation, the switching on / off of protection due to the phase sequence disturbance is carried out by the switch **≡**, and the switching on / off due to the phase imbalance protection - by the switch **■**. If the phase is broken or the voltage drops below 100 V in one or more phases, the device will operate (turn off), the corresponding phase indicator will turn off.

If switches **Umin**, **Umax**, **≡**, **■** are in ON position and the voltage drop is less than **Umin**, the device will operate with the fixed delay of 12 seconds (setting the starting voltage slumps).

## 4. MAINTENANCE

### 4.1. Safety precautions



**THE TERMINALS AND THE DEVICE INTERNAL ELEMENTS CONTAINS POTENTIALLY LETHAL VOLTAGE.**

**DURING MAINTENANCE IT IS NECESSARY TO DISABLE THE DEVICE AND CONNECTED DEVICES**

**FROM THE MAINS.**

**4.2.** Maintenance of the device must be performed by the skilled professionals.

**4.3.** Recommended frequency of maintenance is **every six months**.

**4.4. Maintenance Procedure:**

- 1) Check the connection reliability of the wires, if necessary, clamp with the force specified in Table 1;
- 2) Visually check the integrity of the housing, in case of detection of cracks and damages take the device out of service and send for repair;
- 3) If necessary, wipe the front panel and the housing of the device with cloth.

**Do not use abrasives and solvents for cleaning.**

**5. SERVICE LIFE AND MANUFACTURER WARRANTY**

**5.1.** The lifetime of the device is 10 years. Upon expiration of the service life, contact the manufacturer.

**5.2.** Shelf life is 3 years.

**5.3.** Warranty period of the device operation is 5 years from the date of sale.

During the warranty period of operation (in the case of failure of the device) the manufacturer is responsible for free repair of the device.

**ATTENTION! IF THE DEVICE HAS BEEN OPERATED IN VIOLATION OF THE REQUIREMENTS OF THIS OPERATION MANUAL, THE MANUFACTURER HAS THE RIGHT TO REFUSE IN WARRANTY SERVICE.**

**5.4.** Warranty service is performed at the place of purchase or by the manufacturer of the device.

**5.5.** Post-warranty service of the device is performed by the manufacturer at current rates.

**5.6.** Before sending for repair, the device should be packed in the original or other packing excluding mechanical damage.

**6. TRANSPORTATION AND STORAGE**

The device in the original package is permitted to be transported and stored at the temperature from minus 45 to +60 °C and relative humidity of no more than 80 %.

**7. ACCEPTANCE CERTIFICATE**

RNPP-312 has been manufactured and accepted in accordance with the requirements of valid technical documentation and classified as fit for operation.

Seal

Head of QCD

Date of manufacture

\_\_\_\_\_

\_\_\_\_\_

**8. CLAIMS DATA**

You are kindly requested, in case of the device return and transfer it to the warranty (post-warranty) service please indicate detailed reason for the return in the field of the claims data.

---



---



---



---

*The Company is grateful to you for the information about the quality of the device and suggestions for its operation.*

For all questions, please contact the manufacturer:

**NOVATEK ELECTRO INDIA PVT. LTD.**

**C-30, Patparganj Industrial Area, F.I.E.**

**Delhi – 110092, INDIA**

**Tel: +91 11 42143253, 43010600**

**Email: [info@novatek-electro.in](mailto:info@novatek-electro.in)**

**Web: <http://www.novatek-electro.in>**

Date of sale: \_\_\_\_\_